

# INDUSTRIAL MASTER STATION

HEAVY DUTY



when communication is **critical**

## FEATURES

- Master station with free access to all extensions and features
- Rugged waterproof and dustproof casing in orange aluminium alloy
- Microphone along with red microphone live lamp
- External loudspeaker. Sound level adjustable with a potentiometer inside the station
- Built-in 10 W (8 ohm) VOX operated power amplifier or external loudspeaker
- Screw terminals for easy connection of installation cables
- Equipped with 4 direct access keys

## DESCRIPTION

This Industrial Master station is a waterproof model designed for humid, dirty and outdoor conditions. The unit can operate in an ambient temperature range from -20° to +50°C (-4°F to +122°F). The station consists of a rugged waterproof and dustproof casing (Ip65) of orange silumin. The front panel is hinged to the back casing to allow easy access during installation and service. The station has screw terminals with labels and the 4 glands allow waterproof and dustproof connection of installation cable and loudspeaker wires.

The station is equipped with an internal electret microphone. The volume is adjustable with a potentiometer located inside the casing. An external 20-70 ohm speaker can be connected or, alternatively, connect an 8-20 ohm speaker for use with the built-in 10 W (8 ohm) VOX operated power amplifier. The power amplifier requires a separate 12 V AC/2 A power supply. The external speaker must be placed at least one meter away from the station. The station is programmable for permanent private mode and is also prepared for connection of an external handset unit.



## SPECIFICATIONS

Ordering Number:	1007086000
Operating voltage	From exchange without power amp. 12 VAC/2 A with power amp.
Cable requirements	2 pair 0.5 mm <sup>2</sup> /24 AWG twisted telephone cable + 1 pair 0.8mm <sup>2</sup> /20 AWG (to transf. if power amp. is used)
Temperature range	-20°C to +50°C, -4°F to +122°F
Humidity range (non-condensing)	10% - 85% RH
Dimensions (W X H X D)	160 x 260 x 100 mm, 6.24" x 14.04" x 4.29"
Classification	IP-65
Finish	Silumin (aluminium alloy), Orange RAL 2004 paint
Max. loudspeaker output, external speaker:	1.5 W (20 ohm), 10 W (8 ohm) w/power amplifier

ORDER NUMBER	DESCRIPTION	SHIP WEIGHT
1007086000	Industrial Master Station, heavy duty (IP-65, external speaker is required)	1.1 kg/2 lb. 7 oz
Accessories:		
VML-1520	Horn Loudspeaker, 15W/20 Ohm, IP-66	1.4 kg/3 lb
VMP-211	Wall Mount Handset Unit (with PTT key), IP-44	0.9 kg/2 lb
VMP-250	Wall Mount Handset Unit (with PTT key), IP-65	0.9 kg/2 lb
EOTRF 10115	220V AC/12 V AC Mains Transformer (for power amplifier option)	1.4 kg/3 lb

## INDUSTRIAL MASTER STATION HEAVY DUTY

Loudspeaker impedance	20-70 ohm external (without pow.amp.), 8-20 ohm external (with power amp.)
Frequency range	500-5000 Hz (+/- 8 dB)
Mic. impedance for external handset	200 - 600 ohm
Gland diameter	2 x PG7 + 2 x Pg9
Connector type	Screw terminals
Indicator	LED (red)

## INSTALLATION

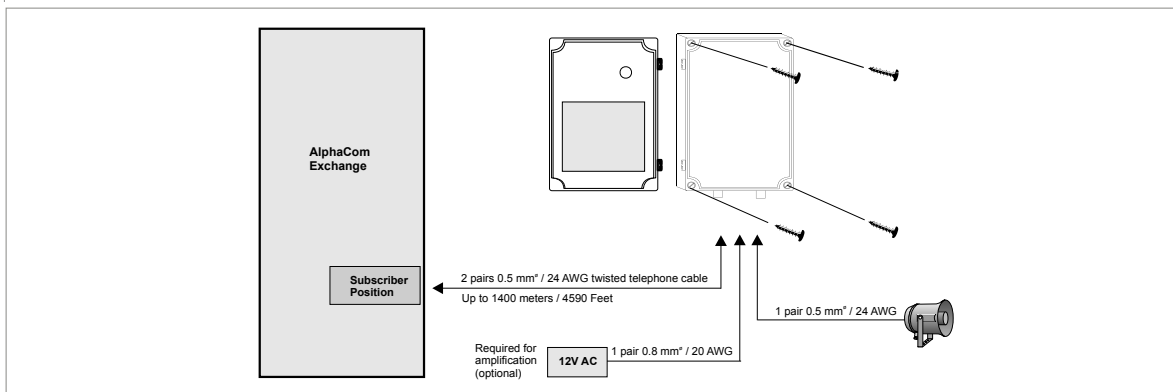

## WIRING

